

INSTALLATION MANUAL

Series MG-300 Horizontal Roller Window

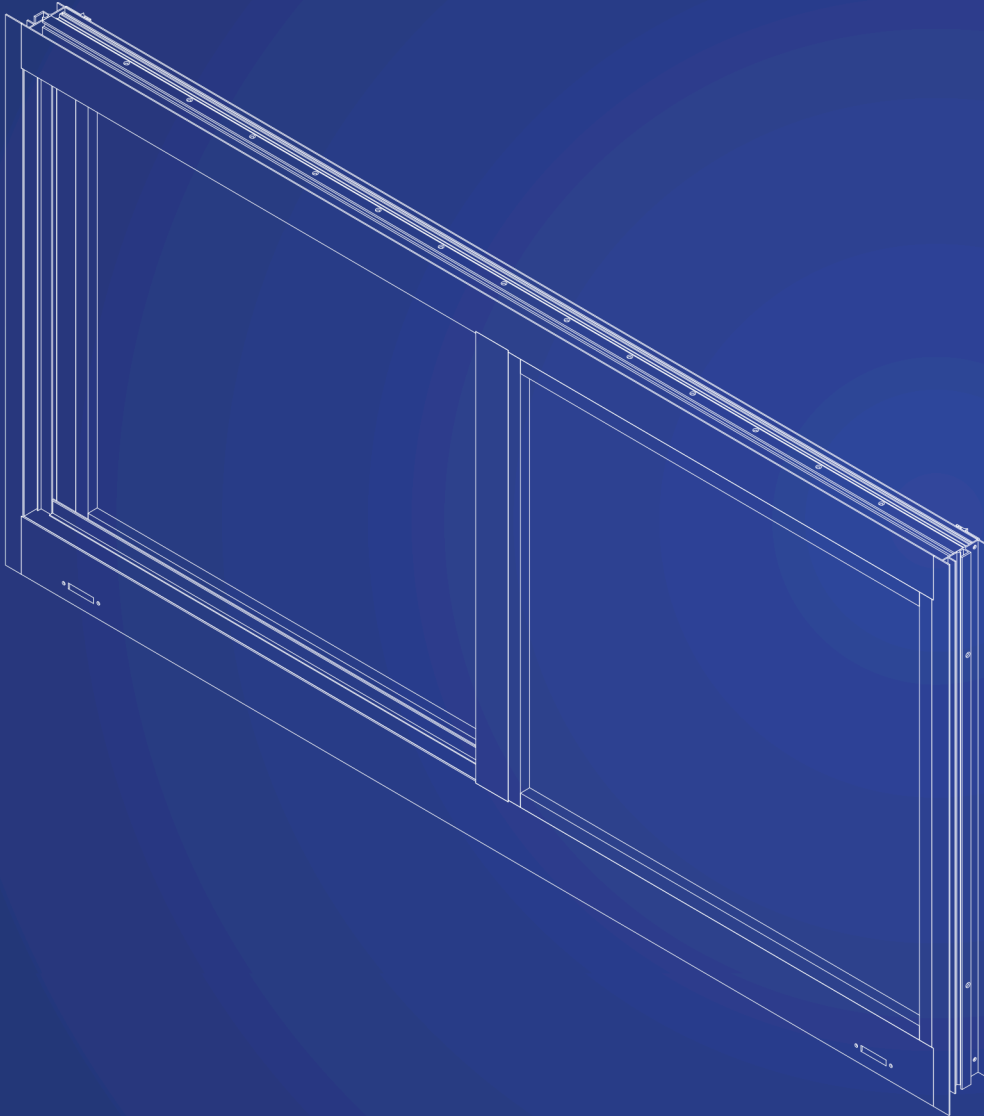

INTRODUCTION

These instructions are provided as general a guide for installation. The Florida Approval of the product (FL20359 LMI and SMI) should be used together with these instructions.

Only professionals and experienced installers should attempt to install these windows.

Read all instructions carefully. If in doubt contact Mr. Glass Doors and Windows. We will be happy to assist.

Use the required protection gear and take all necessary safety precautions depending on the type of installation. Take special care when working at heights.

TYPE OF INSTALLATION

The Horizontal Roller window MG300 features a frontal flange to install on wood buck or specially shaped concrete sill.

With the help of a flush adapter it can also be installed as a box frame on a flat substrate.

In constructions with extreme wind and water exposure, Mr. Glass recommends that masonry openings be treated with liquid flashing and sealed per standards FMA/AAMA 200-12 and FMA/AAMA/WDMA 400-13. That is not mandatory per code and depends on the specifications of the project.

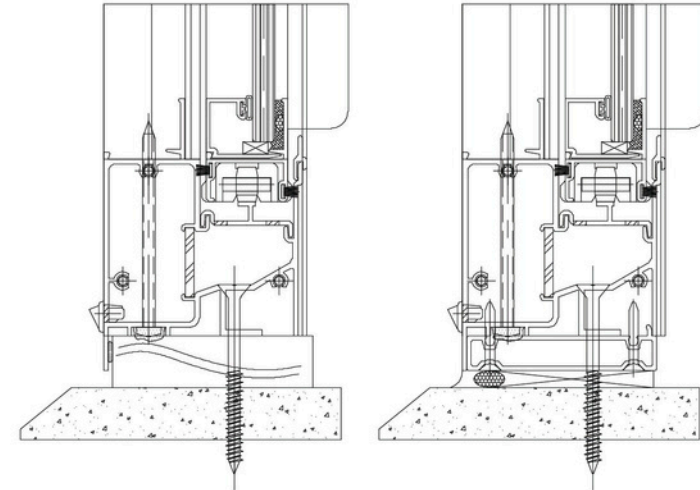

INSPECTION OF THE OPENING

This is the first step and must be executed regardless of the type of installation:

- A. Verify that the opening has the correct dimensions. That it is square, plumb and true. No more than 1/4" difference in square (diagonals) is acceptable. The dimensions of height and width should be within 1/8" of the nominal opening dimension.
- B. In case of masonry openings check for cracks or missing mortar, mainly in the sill that might eventually allow water and humidity migration. Clean any residue of mortar. Any defect should be addressed and corrected by the trade responsible for the opening.
- C. In case of masonry openings check for cracks or missing mortar mainly in the sill that might eventually allow water and humidity migration. Clean any residue of the mortar. Any defect should be addressed and corrected by the trade responsible for the opening.
- D. Check the shop drawings and verify that the opening preparation follows the specifications.
- E. In case the installation is with wood buck, verify that a proper seal has been applied all around between the wood and the masonry. Also verify that the wood bucks touch each other and that they have been sealed to one another.
- F. The wood buck opening dimensions should be verified. It should be plumb, square and true. In case of detecting any defects, do not install until the issue is corrected.

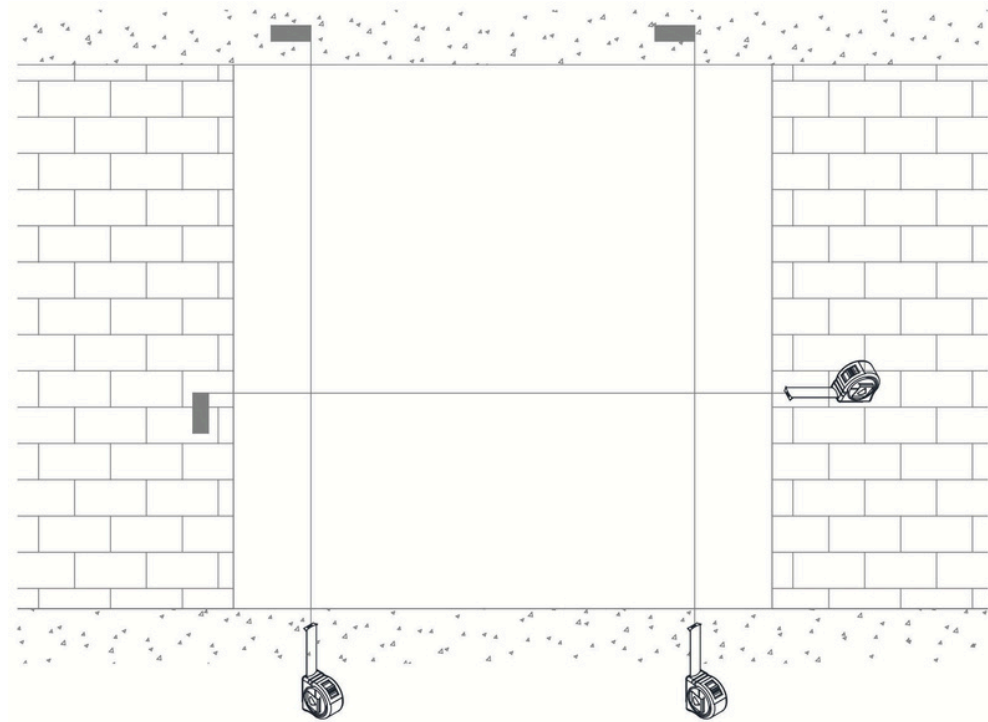

WOOD BUCK INSTALLATION

- A. Use only pressure treated wood buck of appropriate dimensions.
- B. The wood buck should be attached to the masonry independently of the window. Quantity and anchor disposition will be according to the engineer's or shop drawings' specifications.
- C. Prior to installation of the buck, apply a 3/8" bead of silicone on the face of the wood buck around the entire perimeter (see figure 3) This seal will be smashed to the masonry opening when the wood buck is applied to it.
- D. When installing the bucks, make sure that they align with the concrete sill (if it is the case) creating a continuous, planar mounting surface for the flanges.
- E. Once the bucks are attached to the masonry, apply a bead of silicone into the exterior perimeter between the wood and the masonry, and into the joinery between the end of the bucks. Tool the sealant ensuring its continuity.
- F. The wood buck opening dimensions should be verified. It should be plumb, square and true. In case of detecting any defects do not install until the issue is corrected

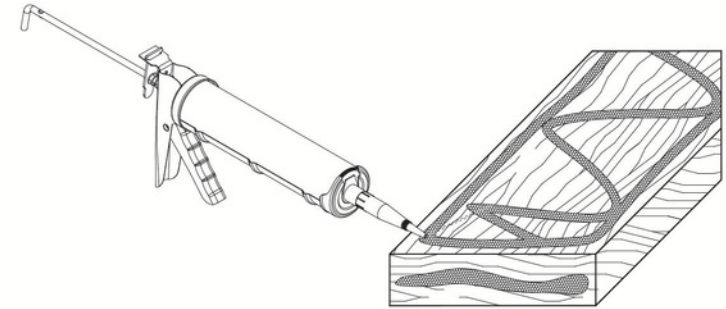

Wood buck Application

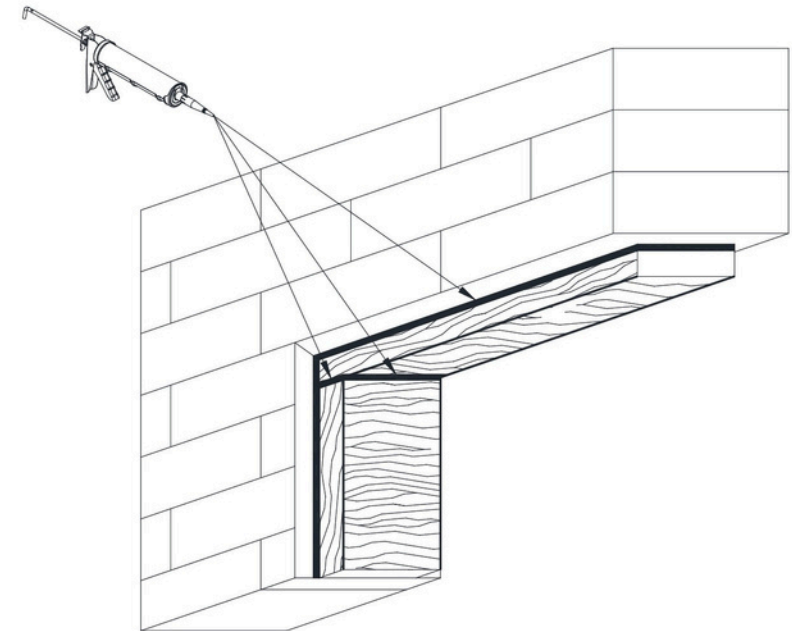

Wood buck seal

UNPACKING THE WINDOW

- A. In case of a retrofit: Before removing any existing window verify that the new window corresponds to the specifications of the project in type and dimensions and that they match the opening size.
- B. Carefully remove the straps and cardboard. Do not use sharp or pointy objects that may damage the aluminum finish or the glass
- C. Verify the window check that everything is correct.
- D. Remove and place the covers, track, and vent in a safe location. To remove the vent, release the lock and move the vent away from the jamb, lift it as necessary and tilt the bottom inward, passing the vent above the back of the sill. To remove the track, carefully lift it by one end to take it out. Note that the track is a slender part, bending it or twisting it can cause damage that will prevent the smooth operation of the vent.
- E. The covers cannot be installed until the anchor installation inspection has been completed and approved by the building official.

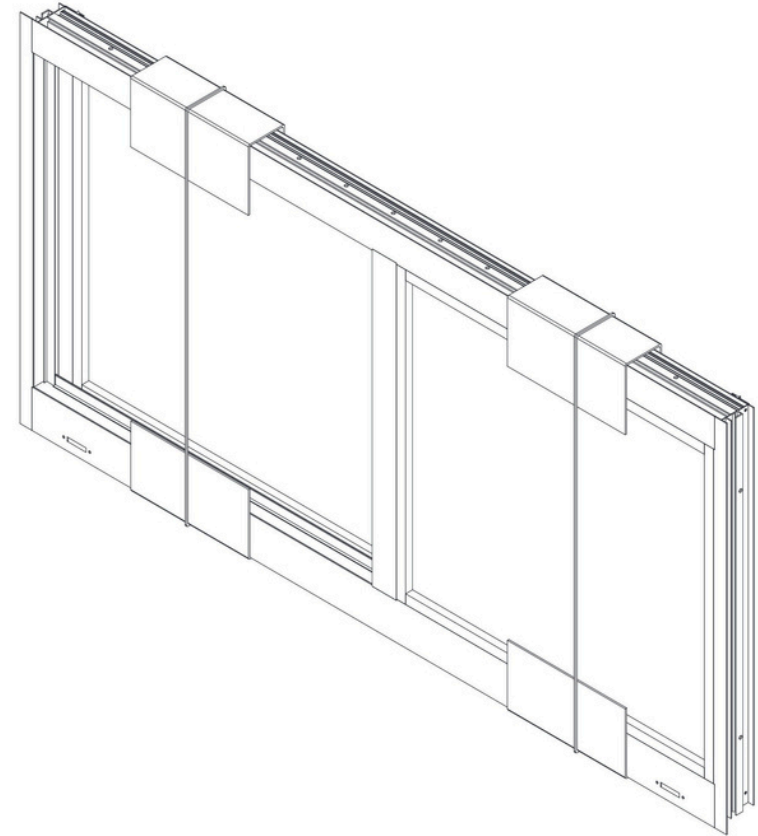

WINDOW INSTALLATION ON WOODBUCK

- A. Carefully remove any residues from the face of the bucks and concrete sill (if that is the case).
- B. Thoroughly inspect the back of the flanges of the window, as well as the corners. They may be misaligned, or a seal may be damaged due to manipulation or transportation movements. Ensure that the connection between flanges is properly sealed and that they are properly aligned.
- C. Inspect the screws located at the bottom of the sill that serve to fix the intermediate rail. Verify that they are thoroughly sealed at the bottom of the sill and internally, inside the sill. This is a critical seal.
- D. Before inserting the window frame into the opening thoroughly clean the interior of the flanges and apply a generous bead of silicone all around the flange perimeter where it will be in contact with the wood buck.

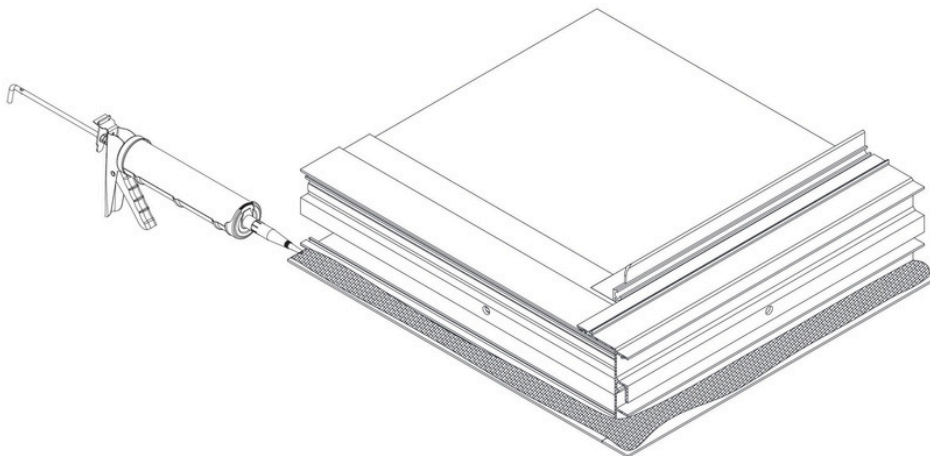

- E. Immediately after, insert the window into the opening. Do not allow for the silicone to start curing, which will occur within a few minutes from application. Insert the shims as required to make the window plumb. To hold it in place use temporary screws to fix the window to the wood buck.
- F. Use the appropriate anchor type and length per Florida Approval. Ensure that each anchor is properly shimmed before applying full torque. Note that the window is provided with a standard hole pattern (spacing) from factory. At certain wind load pressures additional anchors may be required at sill and head. The current Florida Approval should be consulted.
- G. See the next section for the anchor length that is required to ensure the appropriate embedment is being provided.
- H. Insert the screws according to the requirements of the Florida Approval. Do not over tighten the anchors as it will cause the sill shape to “close” locally, creating friction between vent and the sill.
- I. Seal all the screw heads. Mr. Glass recommends applying sealant directly on the hole prior to inserting the anchor. That ensure that the silicone is at the base of the screw head when tightening. Apply silicone on top of the anchor as well once tightened.

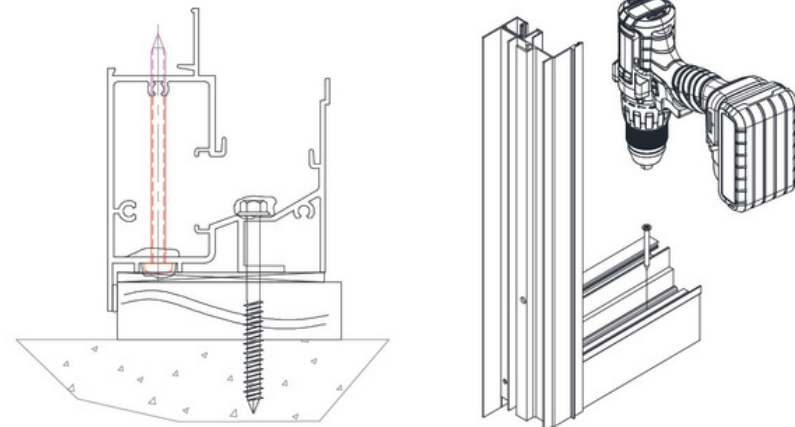

- J. Verify the plumb, level and square.
- K. Reinsert the track and vent back into the window frame. Test the proper function of the locks and that the vent slides smoothly.
- L. Tool the overflowing silicone from the flange extending it over the buck. Make sure that the exposed surface of the wood buck is covered with silicone. Apply extra silicone if required (this does not apply to openings treated with liquid flashing).
- M. Install the vent top and covers. Verify that the vent locks/unlocks and operates satisfactorily.

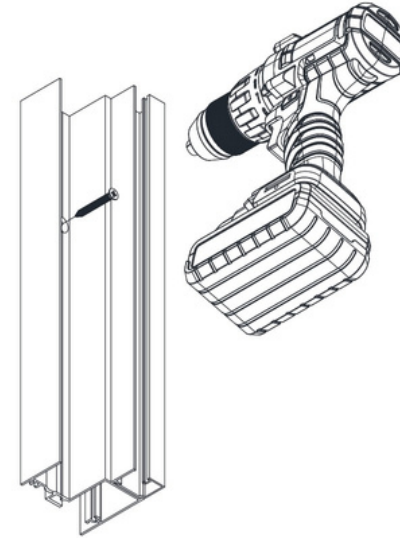

WINDOW INSTALLATION WITH FLUSH ADAPTER. (BOX FRAME)

- A. Carefully remove any residue from the masonry opening and concrete sill (if that is the case).
- B. Thoroughly inspect the back of the flanges of the window, as well as the corners. They may be misaligned, or a seal may be damaged due to manipulation or transportation movements. Ensure that the connection between flanges is properly sealed and that they are properly aligned. Apply a generous silicone bead all along the flange, around the window.
- C. Inspect the screws located at the bottom of the sill that serve to fix the intermediate rail. Verify that they are thoroughly sealed at the bottom of the sill and internally, inside the sill. This is a critical seal.
- D. Clean the face of the flush adapter that will be in contact with the interior of the flange of the window and put together using # 8 screws.
- E. Insert the frame in the opening. You may temporarily hold it with temporary screws to make it plumb, leveled and squared. Place shims where required.
- F. Use the appropriate anchor type and length per Florida Approval. Ensure that each anchor is properly shimmed before applying full torque. Note that the window is provided with a standard hole pattern (spacing) from the factory. At certain wind load pressures additional anchors may be required at sill and jambs. The current Florida Approval should be consulted.
- G. See in the next section for the anchor length that is required to ensure that the appropriate embedment is being provided.
- H. Seal all the screw heads.
- I. Verify that it is plumb, level and square

- J. To seal the perimeter use open cell backer rod as required. Apply sealant all around and project the seal up and out to cover the flange 14".

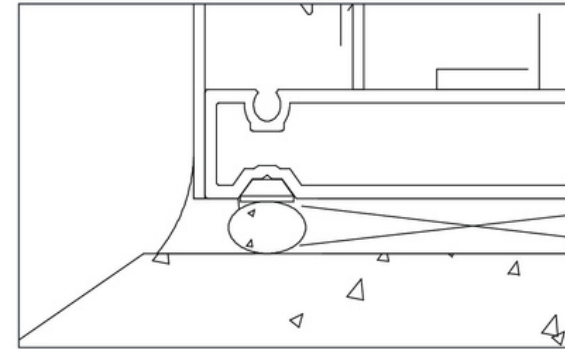

- K. Reinsert the track and vent back into the window frame. Test the proper function of the locks and that the vent slides smoothly.

WINDOW CLEANING

- A. Once the installation is complete proceed to clean the window. Mr. Glass recommends using water and mild soap or detergent.
- B. Consult Service Bulletin 01-2021 "Maintenance of coated surfaces" and 02-2021 "Glass Cleaning Recommendations".
- C. Do not use sharp objects that may damage the finish in the aluminum or scratch the glass
- D. Remove all temporary seals and logos.
- E. Clean the work area and dispose of all packaging residue.

